

Model 8515C -15, -50 Piezoresistive pressure transducer

Features

- 15 to 50 psia, 200 mV full range
- Low profile, 0.030 inch thin
- Absolute reference



Description

The Endevco® model 8515C is a rugged, miniature, high sensitivity piezoresistive pressure transducer available in 15 and 50 psia full scale ranges. It is surface-mounted and measures 0.030 inch thin by 0.250 inch diameter (0.76 mm x 6.3mm). Full scale output is 200 mV with high overload capability, high frequency response, very low base strain sensitivity and excellent temperature performance.

Because of its very small size, the model 8515C can be installed on curved surfaces with minimal effect on laminar air or hot gas flow. For a flush fit, the 8515C and leadwires can be recessed into the mounting surface. A protective screen is provided to protect against particle impingement. The model 8515C is suitable for use on small-scale models in wind tunnel tests, as well as on aerodynamic surfaces during flight tests. Other uses include helicopter or turbine blade surface pressure measurements.

A rubber fairing, part number 30042, is an available accessory for airflow smoothing for flight test applications. Modified versions are available on special order for wider temperature compensation.

Endevco model 136 three-channel system, model 4428A or 4430A signal conditioner, or OASIS 2000 computer-controlled system are recommended as signal conditioner and power supply.

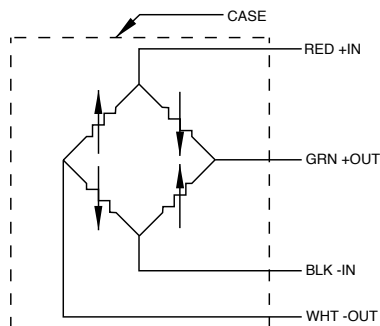
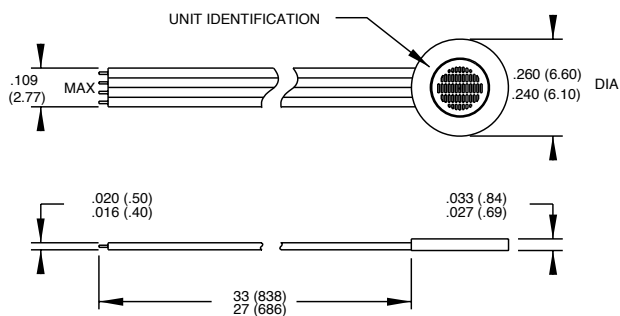

STANDARD TOLERANCE
INCHES (MILLIMETERS)
.XX = +/- .03 (X = +/- .8)
.XXX = +/- .010 (XX = +/- .25)

Model 8515C -15, -50 Piezoresistive pressure transducer

Endevco

Specifications

Certified performance: All specifications assume +75°F [+24°C] and 10 Vdc excitation unless otherwise stated. The following parameters are 100% tested. Calibration data, traceable to the National Institute of Standards and Technology (NIST), is supplied.

Dynamic characteristics	Units	8515C-15	-50
Range [1]	psia	0-15	0-50
Positive sensitivity [2]	mV/psi typ (min)	13.3 [8.67]	4.0 [2.6]
Combined: non-linearity, non-repeatability, pressure hysteresis [3]	% FSO RSS max	0.50	0.50
Non-linearity, independent	% FSO typ	0.20	0.20
Non-repeatability	% FSO typ	0.1	0.1
Pressure hysteresis	% FSO typ	0.1	0.1
Zero measurand output [4] [5]	mV max	±20	±20
Zero shift after 3X range	% 3X FSO max	0.5	0.5
Thermal zero shift [6]			
from 0 °F to +200 °F (-18 °C to +93 °C), Ref to 75 °F [24 °C]	% FSO max	2.5	2.5
Thermal sensitivity shift [4] [6]			
from 0 °F to +200 °F (-18 °C to +93 °C), Ref to 75 °F [24 °C]	% max	3	3
Resonance frequency [7]	Hz	180 000	320 000
Non-linearity at 3X range	% 3X FSO	1.0	1.0
Thermal transient response per ISA-S37.10, para. 6.7, procedure I [8]	psi/°F	0.003	0.005
Photoflash response	psi	0.25	0.8
Warm-up time [10]	ms	1	1
Acceleration sensitivity	psi/g	0.0002	0.0002
Burst pressure (diaphragm)	psia min	75	250
Base strain sensitivity at 250 microstrain			
Elastomer mounting [11]	psi	0.004	0.013
Rigid mounting [12]	psi	0.007	0.023
Electrical			
Full scale output	200 mV typical (130 mV minimum) at 10.0 Vdc		
Supply voltage [13]	10.0 Vdc recommended, 12 Vdc maximum		
Electrical configuration	Active four-arm piezoresistive bridge		
Polarity	Positive output for increasing pressure		
Resistance			
Input	2700 ohms typical, 2000 ohms minimum		
Output	1500 ohms typical, 2200 ohms minimum		
Isolation	100 megohms minimum at 50 volts; leads to case, leads to shield, shield to case		
Noise	5 microvolts rms typical, dc to 50 000 Hz; 50 microvolts rms maximum, dc to 50 000 Hz		
Mechanical			
Case material	Stainless steel 300 series CRES		
Cable, integral	4 conductor No. 36 AWG solid S.P.C., Teflon® insulated		
Dead volume [7]	0.0004 cubic inches (0.0065 cc)		
Mounting [11] [14]	RTV bond to flat surface		
Weight	0.08 gram (cable weighs 2.5 grams/meter)		
Environmental characteristics			
Media	The pressure cavity of this transducer model is designed to be compatible with dry, clean gases. It is not recommended for use in water or moisture condensing environments. When the pressure media is believed to be degrading to the transducer the factory should be contacted for appropriate recommendations. Pressure media is exposed to CRES, epoxy, silicon and parylene C.		
Temperature	-65 °F to +250 °F (-54 °C to +121 °C)		
Vibration	1000 g		
Acceleration	10 000 g		
Shock	10 000 g, 100 microsecond haversine		
Humidity	The transducer is not recommended for long term operation in humid environments. Consult factory for optional protective coating.		



Model 8515C -15, -50 Piezoresistive pressure transducer

Endevco

Calibration data supplied

Data supplied for all parameters in Certified Performance section. Optional calibrations available for all parameters in Typical Performance section. A transducer test report is provided with each transducer shipped.

Optional accessories

30042	Mounting pad
EW862	4 conductor ribbon cable

Notes:

1. 1 psi = 6.895 kPa
2. A precise value for sensitivity is measured and provided for each unit.
3. FSO (Full Scale Output) is defined as transducer output from 0 to +FS, which is nominally 200 mV.
4. Tighter specifications are available on special order.
5. Zero Measurand Output (ZMO) is the transducer output with 0 psia applied.
6. Units can be compensated over any 200°F (93°C) span from -65°F to +250°F (-54°C to +121°C) on special order.
7. The cavity in the housing around the diaphragm may result in a low amplitude minor resonance near 70 kHz.
8. Significantly higher thermal transient errors occur if the excitation voltage exceeds 10 Vdc. For sensitive phase change studies, many users reduce the excitation voltage to 5 or even 1 volt.
9. DELETED
10. Warm up time is defined as lapsed time from excitation voltage "turn on" until the transducer output is within 1% of reading accuracy.
11. Recommended mounting is .002 to .005 inch thickness of an RTV adhesive, such as Dow Corning Silastic® 738, or General Electric RTV 118.
12. Rigid mounting using cyanoacrylate adhesive. Use of a rigid adhesive makes removal without damage extremely difficult.
13. Use of excitation voltages above 10 Vdc requires manufacture and calibration at that voltage since thermal errors increase with high excitation voltages. If the unit is operated in a vacuum, excitation voltages above 10 volts may damage the unit.
14. Extreme care must be exercised in order to remove a mounted unit without damage. Use of solvents to remove the mounting adhesive may damage joints in the case of the unit.
15. Model number definition:

8515C-XX-ZZZ

- └ Cable length in inches (i.e. 8515C-XX-120 has a cable length of 120 inches) if no length is specified, default length is 30 ±3 inches)
- └ Denotes pressure range
 - 15 = 15 psia
 - 30 = 30 psia

16. Maintain high levels of precision and accuracy using Endevco's factory calibration services. Call Endevco's inside sales force at 800-982-6732 for recommended intervals, pricing and turnaround time for these services as well as for quotations on our standard products.

NOTE: Tighter specifications are available on special order.



Continued product improvement necessitates that Endevco reserve the right to modify these specifications without notice. Endevco maintains a program of constant surveillance over all products to ensure a high level of reliability. This program includes attention to reliability factors during product design, the support of stringent Quality Control requirements, and compulsory corrective action procedures. These measures, together with conservative specifications have made the name Endevco synonymous with reliability.

© ENDEVCO CORPORATION. ALL RIGHTS RESERVED 30700 RANCHO VIEJO ROAD, SAN JUAN CAPISTRANO, CA 92675 USA
[800] 982-6732 • [949] 493-8181 fax [949] 661-7231 • www.endevco.com • Email: applications@endevco.com

020310

MEGGITT
smart engineering for
extreme environments